

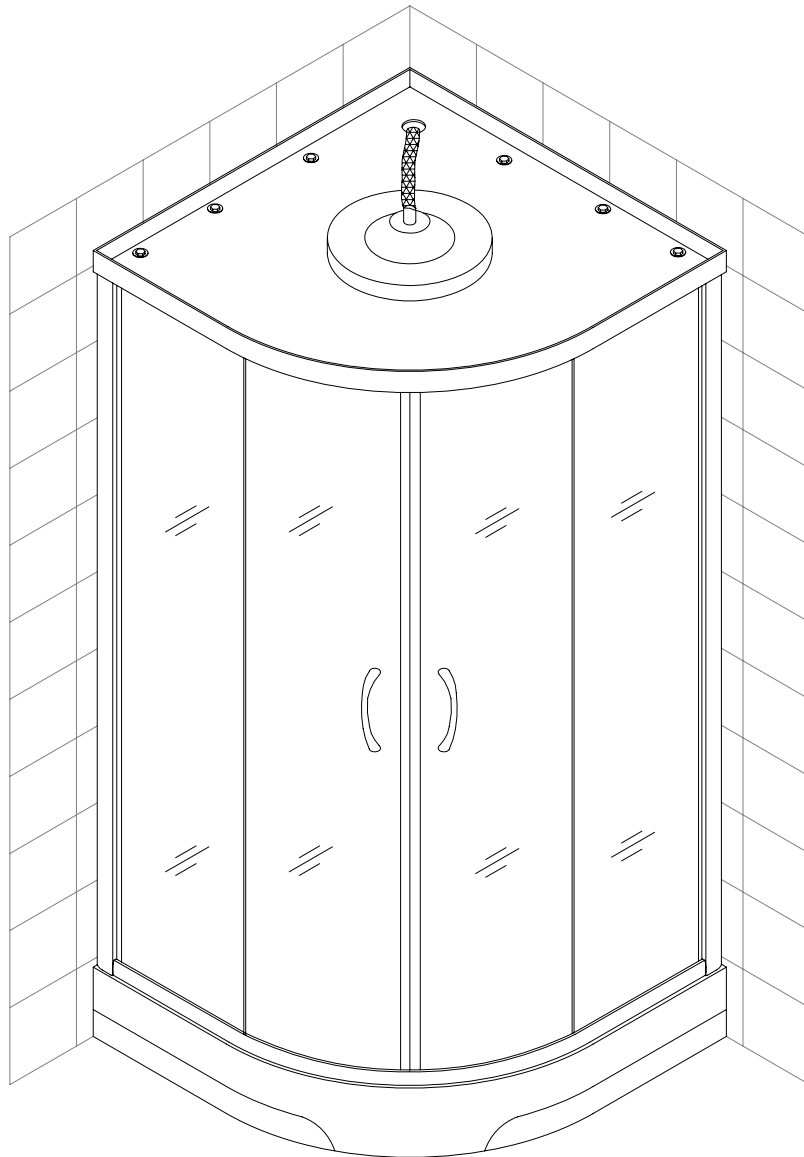

ATLANTICA Shower Cabin Installation Instructions

IMPORTANT

Please read carefully the following instructions before installing your shower cabin. If you have any questions on this shower cabin installation - please call our technical support specialists Monday to Friday 9:00AM – 5:00PM EST at 1-866-731-8378 Option 3 or e-mail our technical support group at support@BathAuthority.com



Our product may have changes without prior notice

Preparation

1. After opening all the boxes, read this introduction carefully, check all the packed parts are complete by cross checking all the components against the “Detailed Diagram of Shower Cabin Components”. Examine for shipping damage. If the unit has been damaged or has a finishing defect, please contact your local distributor within 3 business days. Please note that **Bath Authority™ / DreamLine™ will not replace any damaged product or parts free of charge after 3 business days or if the product has been installed.** Contact your distributor or distributor if you have any questions.
2. **Please note that you should consult your local building codes on questions on installation compliance standards. Building and plumbing codes vary by location, and DreamLine is not responsible for code compliance standards for your project.**
3. Install all of the required plumbing and drainage before securing the shower. **Use a competent and licensed (if required by local code) plumber for all plumbing installation.**
4. Please insure that prior to the installation the floor is leveled and solid and will be able to support the total weight of the unit and its occupant. Also make sure the walls are at right angles. While some adjustment in leveling of the tray is possible, irregular floor level or improper angle of side walls will result in serious problems for your installation. Please, note that there are some adjustments and drilling might be necessary during the installation process.

Tools Required

Electric drill, Pencil, Phillips screwdriver, Slotted screwdriver, 3/8 Wrench, 3/8 Socket, Tape measure, Spirit level with horizontal and vertical indicators.

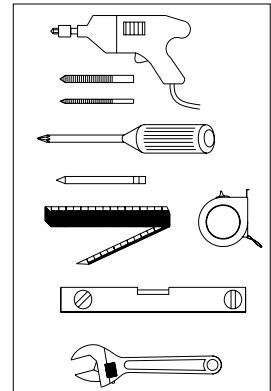

Detailed Diagram of Shower Cabin Components

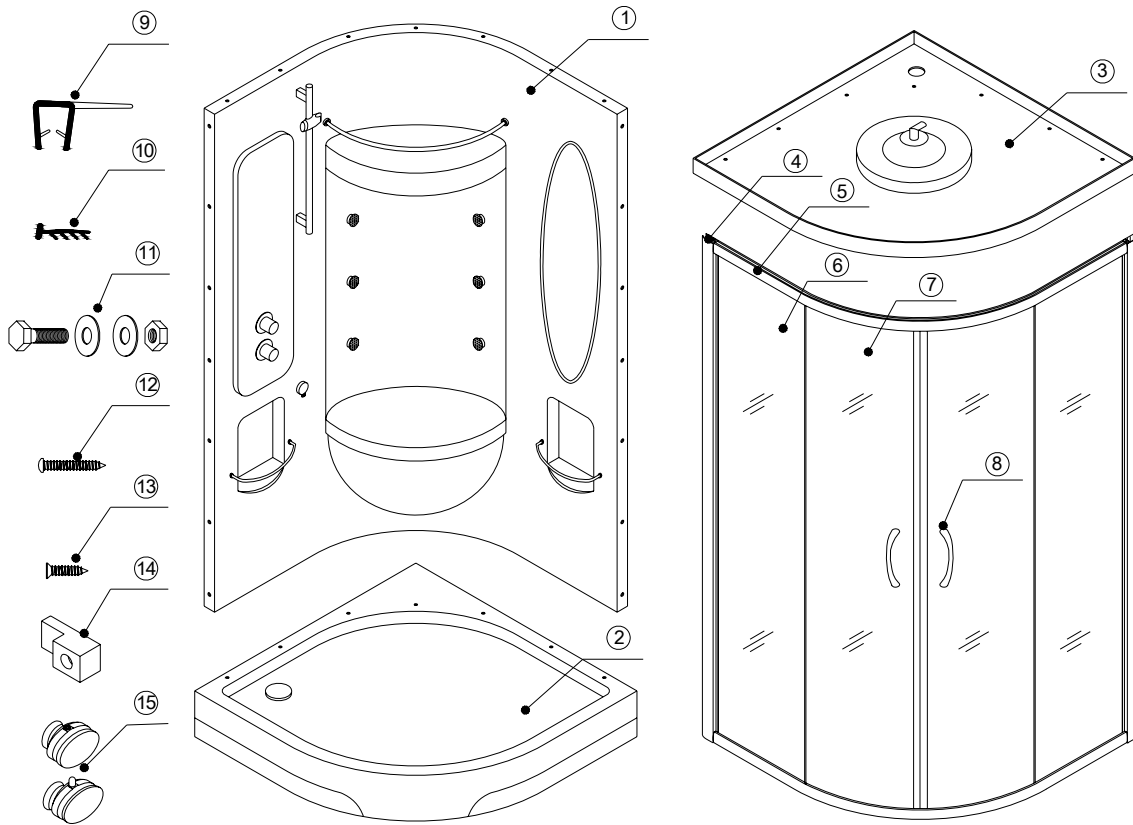

Packing List

| | | | | | |
|----|-----------------------------------|---------|----|---|---------|
| 01 | Back panel | 1 pc | 10 | Single side strip | 2 pcs |
| 02 | Bottom tray | 1 pc | 11 | M6×16 bolt set with nuts, washers | 14 sets |
| 03 | Roof kit* | 1 pc | | M6×20 bolt set with nuts, washers | 15 sets |
| 04 | Vertical profile | 2 pcs | 12 | Round head self-tapping screw ST4.2×30 | 8 pcs |
| 05 | Guide rail with attached stoppers | 2 pcs | 13 | Flat head self tapping screw ST4.2×15 | 4 pcs |
| 06 | Stationary glass | 2 pcs | 14 | Stationary glass holder | 4 pcs |
| 07 | Glass door | 2 pcs | 15 | Wheel assembly | 4 pairs |
| 08 | Handles | 2 pairs | 16 | Hand shower | 1 pc |
| 09 | Anti-water strip | 4 pcs | | | |

* Roof Kit is sold separately and includes the “tropical rain” head shower, brass L-adapter, nylon hose, M6×16 bolt set with nuts, washers (7 pcs).

Now that you have checked that all listed components are there, you are now ready to start the installation of your Dreamline shower cabin.

Cabin Installation

1. Choose the location where you will be installing the tray, mark the location of the tray because you may need to move it out from the position for better assembling procedure. Check on the drain if it is fastened tight enough to make sure it won't leak after complete tray installation.
2. Also check all the hose connections to prevent leakage. Your plumber may want to replace the drain flex hose to hard PVC pipes which is also possible (instructions are provided in the manual).
3. For installation of the drain in the floor please refer to the **Legs and frame position (top view)** fig 1 (actual position of the drain and frame on the tray).
4. Secure the two vertical profiles and the bottom guide rail with ST4.2×30 round head self tapping screws (fig 2);
5. Fasten the top guide rail to the vertical profiles with ST4.2×30 round head self tapping screws.
6. Insert the stationary glass panels into the frame of the vertical profiles and the guide rails. Use the stationary glass holders to secure the glass in the frame. Tap in the single side strip to make the connection waterproof (fig 3);
7. Place the tray in the required position. You may need to take off the front skirting panel for easy access. Adjust the legs to level the tray in case the surface is uneven. Fasten the counter nuts on the legs to secure the height (fig 4);
8. Move the tray out. Clean the surface of the tray threshold and apply a layer of silicone on to the edge; put the back panel onto the tray and fix them with M6×20 bolt sets (fig 5 & 6);
9. Clean the front threshold of the tray and apply a layer of silicone. Put the glass enclosure assembly onto the tray and adjust the position. Use M6×16 bolt sets to connect the vertical profiles and back panel (fig 7);
10. This step applies to those units that came with the roof kit:
Clean the top surface of the built enclosure assembly and apply a layer of silicone. Put the roof on the fixed shower enclosure and using M6×20 bolt sets connect it to the back panel; (fig 8);
If your unit came without roof kit, please, make sure there is a block nut secured on the top valve on the back of the wall.
11. Your unit can be shipped to you with the wheel assemblies installed on the doors. If not, please refer to diagram (fig 9) how to install it. Attach the top and bottom wheels to the glass doors. The wheel that goes on the top has an adjustable screw and nut to adjust the door level. Note that the lock nut of upper wheel should face up. The bottom wheel has a press button to fix the wheel on the bottom guide rail; that button should face up (fig 9);
12. Secure the handles to the doors. Slide the top door wheels into the top guide rail and push the bottom wheels in the bottom guide rail by pressing down the button. Attach the magnetic strips to the glass doors. Use the Phillips screwdriver #2 (**do not use power screwdriver**) to adjust the upper wheels, make sure they move smoothly and the doors close tight. Then attach the anti-water strips (fig 10);
13. Seal with silicone on all the connections between the vertical profiles and the back panel, bottom rail and tray, tray and back panel. Let it dry for 24 hours before moving the cabin;
14. Connect the flexible hose to the hand shower. Secure this item in place on the back panel. Secure the top shower head on the roof. Make sure all the water connections are water tight;
15. Connect hot water to the red mark water inlet and cold water to the blue mark water inlet (fig 11). Connect the drain flexible pipe (1 ½" outlet) to the drain opening in the floor;
16. Do not move the cabin into the place until you check all the components for any leakage or problems; open each valve to see how it works, check thermostatic valve

for hot and cold water. You may need to tight some connections (during storage and transportation connections may get loose). If you do not see any leakage, then you can move it to the permanent position, attach the front skirting panel and finish your project.

One of the ways on how to change flex hose to hard PVC pipes:

Disconnect the flex hose from the shower drain unit. Fasten the 1 1/2" hard PVC pipe to the drain. Using the trap adaptor with washer and plastic nut fasten the PVC pipe to the adaptor from 1 1/2" to 2".

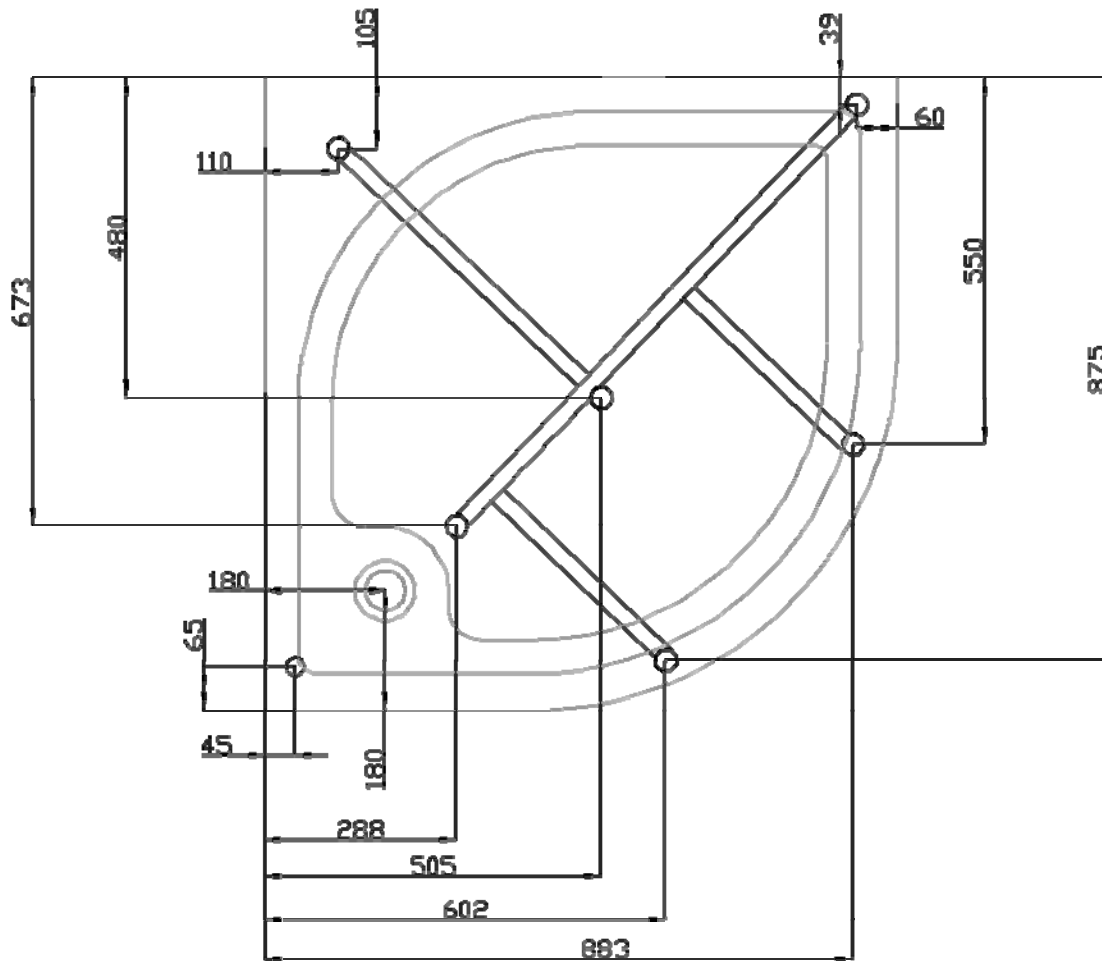

Fig 1 Legs and frame position (top view)

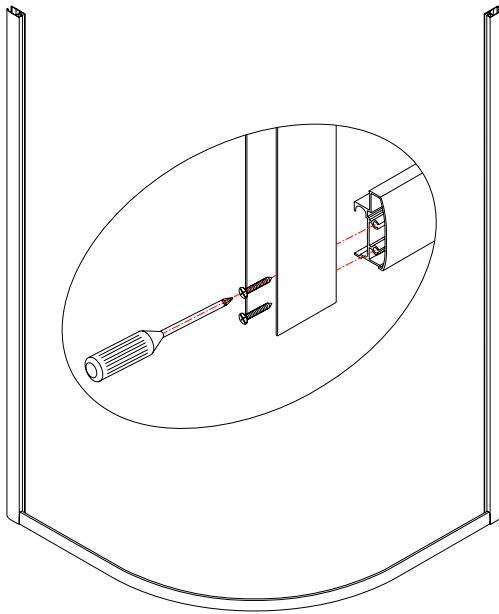

Fig 2

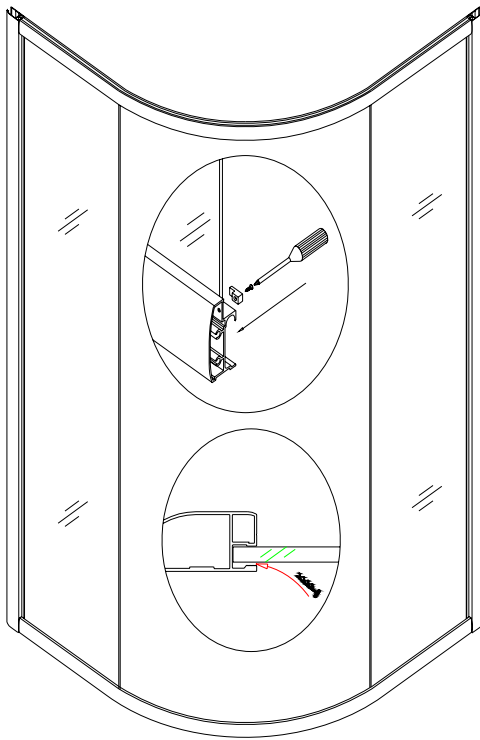

Fig 3

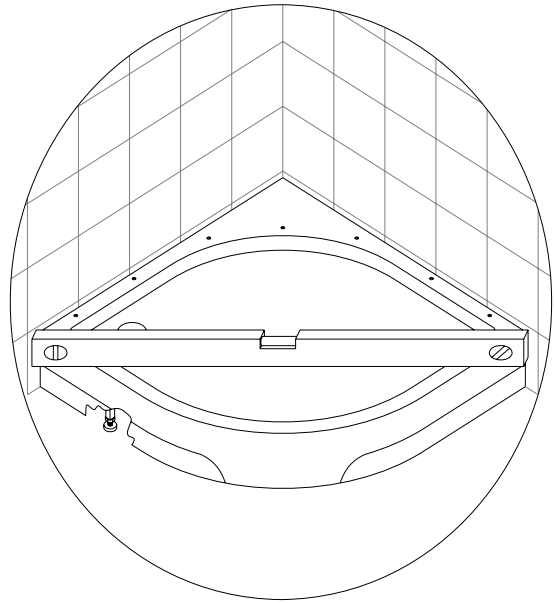

Fig 4

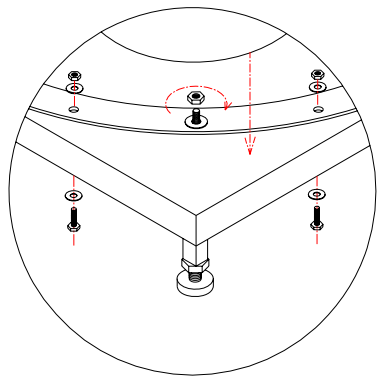

Fig 5

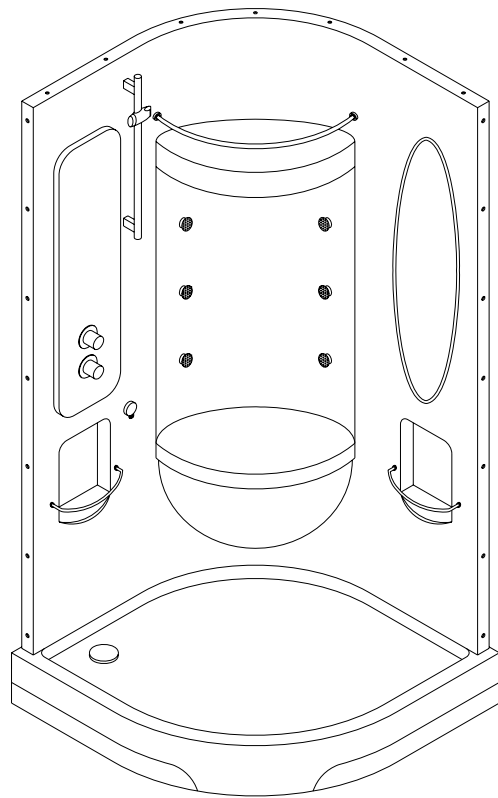
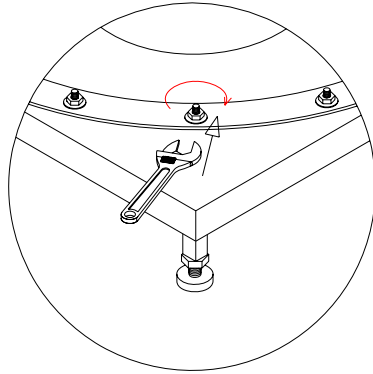

Fig 6

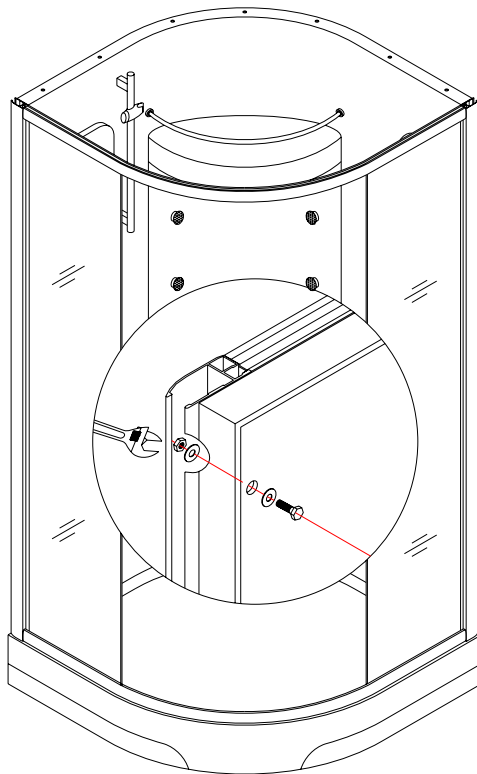

Fig 7

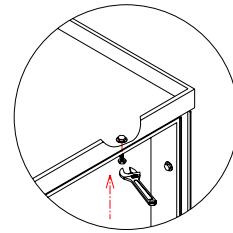
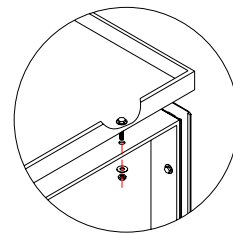
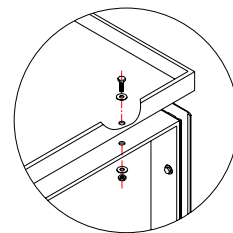

Fig 8

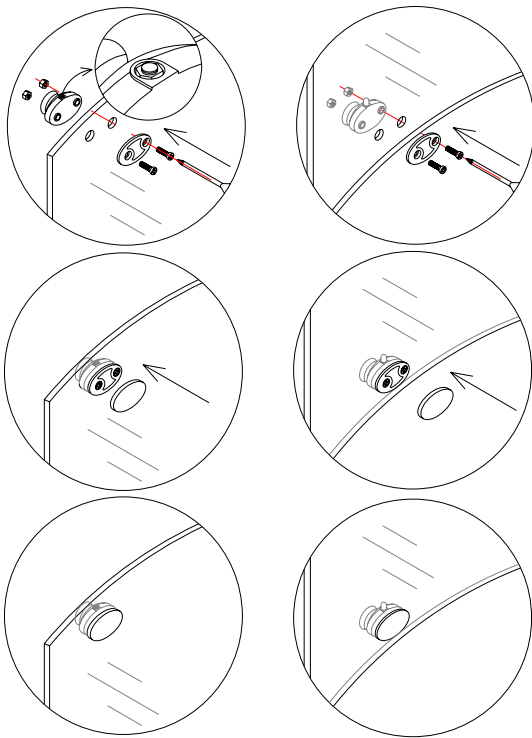

Fig 9

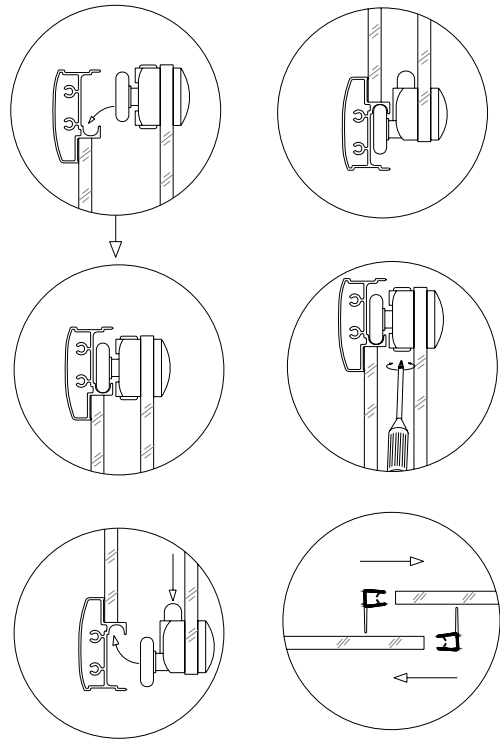

Fig 10

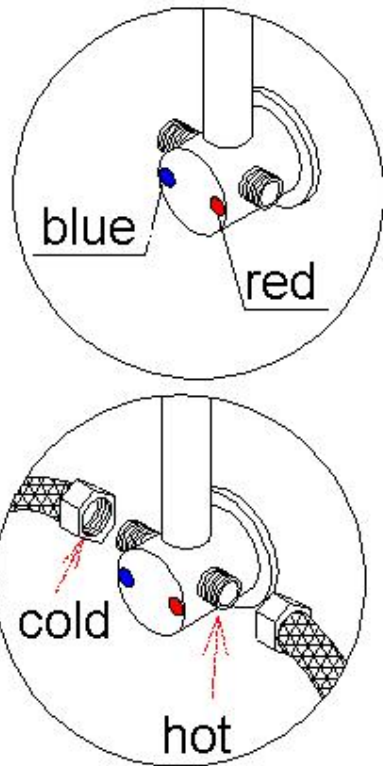

Fig 11

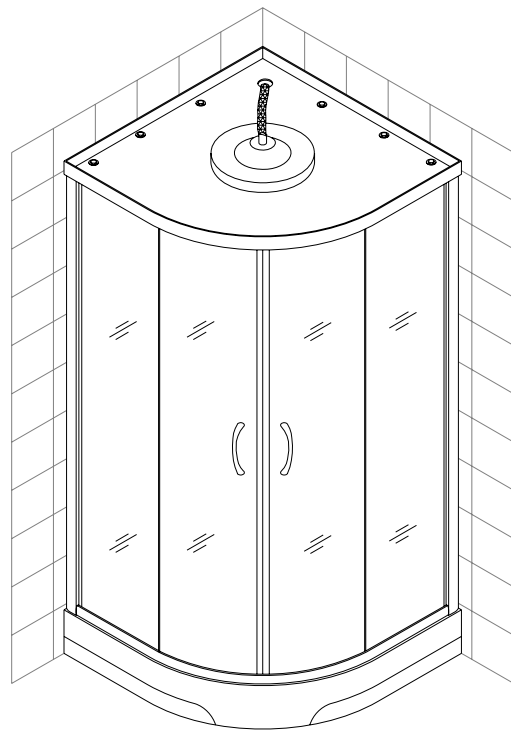
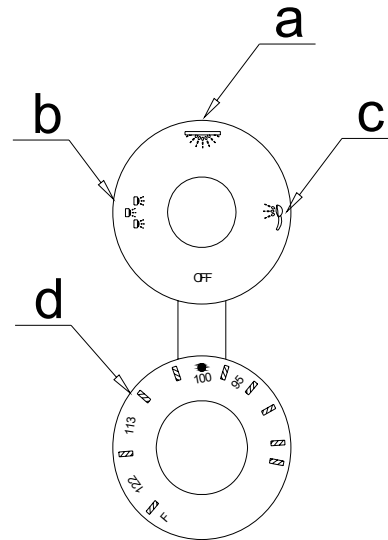

Fig 12

Using controls

Top valve has three positions:

- When it's in position "a" – it turns on water of the "tropical rain" head shower.
- When it's in position "b" – it turns on water of eight massage jets.
- When it's in position "c" – it turns on water of the hand shower. Turn the revolve cover of the shower head will change water pattern.
- Thermostatic valve "d" adjusts water temperature on any valves you are using.



Product maintenance

Acrylic cleaning. Acrylic should be cleaned with warm water and a clean, nonabrasive cloth. If desired, a mild, nonabrasive detergent may also be used. Use only light pressure when cleaning. Avoid rubbing dirt or grit into the surface. Turn the cloth often and replace with a clean cloth frequently. Dry by blotting gently with a clean, dry cloth.

DO NOT USE window cleaning sprays, alcohol, kitchen abrasive compounds, or solvents (such as acetone, gasoline, or thinners). Do not use ammonia based cleaning solutions on the acrylic as it will eat into the surface and cause it to damage.

How do you get scratches out of Acrylic? For light scratches, use a buffing compound such as car wax, using the buffer provided slightly buff the surface by hands until scratches disappear.

Glass cleaning. Use any normal household glass cleaning product such as Windex to clean your glass. Be **careful of overspray and wipe off any that gets on the frame.**

Aluminum maintenance. Use mild cleaning agent dipped soft cloth mop off all dirty and dust on glass. Do not use abrasive cleaning agent or polishing wax, alcohol, acetone etc.

Bath Authority™ LLC / DreamLine™ Shower Enclosure, Jetted/Steam Shower and Shower Columns Limited Warranty

CONSUMER RESPONSIBILITIES

Your DreamLine™ Shower Products will remain beautiful for many years if you take care of them. Some of the waterproofing plastic strips and other seals will need to be replaced when they show signs of wear, yellowing, or are not watertight. Refer to the parts list of your manual for all seals. Water conditions in various parts of the country will determine any extra cleaning attention you may have to give your new shower enclosure or jetted shower. DreamLine™ does not recommend the use of harsh abrasive cleansers on any of its products. Harsh cleansers will damage the metal or glass finish on your shower enclosure or jetted shower.

REQUESTING SERVICE

Here's what you need to do if you require service:

1. Contact the dealer who sold and/or installed the product. They should be able to solve any problems you may have.
2. If your dealer or contractor cannot solve the problem, they will contact or supply you with the name of the local DreamLine™ Distributor or a DreamLine™ Direct Technical Specialist
3. If you are unable to obtain warranty service through either your contractor or DreamLine™ distributor, please write us directly at

Bath Authority™ LLC / DreamLine™

909 Louis Drive

Warminster, PA 18974

ATTN: Customer Service Department

4. Include all pertinent information regarding your claim, including a complete description of the product, model numbers, colors, finishes, and the date the product was installed. Include a description of the problem and a photocopy of your invoice and purchase receipt(s) for the products involved. Also please provide information on the name and contact telephone numbers of the contractor and distributor.

Please note that under any circumstances, DreamLine™ products should not be returned to your dealer, distributor or directly to DreamLine™ without a written Return Merchandise Authorization (RMA).

LIMITED ONE-YEAR WARRANTY

This warrantee extends only to the original owner/end-user for personal household use only. For commercial uses, additional limitations may apply.

DreamLine™ warrants acrylic surface against blistering or cracking and chipping resulting from defect in the acrylic surface material when used under normal condition and service for a period of one (1) year from the purchase date.

DreamLine™ warrants mirrors, shower doors, shower massage systems, faucet finishes and fittings to be free from defects in workmanship and materials under normal use and service for a period of one (1) year.

DreamLine™ further warrants the structure of the acrylic shell against loss of water through the fiberglass laminate of the acrylic body as a result of defect in materials and workmanship for a period of five (5) years from the purchase date.

DreamLine™ will, at its election, repair, replace, or make appropriate credit adjustment where DreamLine™ optional inspection discloses any such defects occurring in normal usage within the warrantee periods.

Please note that DreamLine™ is not responsible for any installation or removal costs.

Improper modification of any enclosure, jetted shower or shower column components may void the warrantee - so please install the product as directed in the manual. This warrantee does not cover any claim arising from abuse, misuse, negligence, accident, improper installation or operations on the part of the purchaser. This warrantee is void if the DreamLine™ product is subject to alterations, or if repairs are attempted by anyone other than an authorized agent of DreamLine™. This warrantee does not extend to any plumbing or components installed by dealers, installers or by any party other than DreamLine™.

Implied warranties, including that of merchantability or fitness for a particular purpose, are expressly limited in duration to the duration of this warranty. DreamLine™ disclaims any liability for special, incidental, or consequential damages.

Some states do not allow limitations on how long an implied warranty lasts or the exclusion or limitation of special, incidental, or consequential damages, so these limitations and exclusions may not apply to you. This warranty gives you specific legal rights. You may also have other rights which vary from state to state. This limited warranty provides specific legal rights as they apply within the USA, and other rights may be available, but may vary from country to country.

This is our exclusive written warranty for DreamLine™ Shower Enclosure, Jetted/Steam Shower and Shower Column purchases made after May 2004. DreamLine™ reserves the right to modify this warranty at any time, and the consumer understands that such modification will not alter the warranty conditions applicable at the time of the sale of the product.